

# A / AN 50Hz SERIES

SUBMERSIBLE WASTEWATER  
SUMP PUMPS



# AN

## FEATURES

- A precision manufactured motor is achieved by utilizing the highest standard of quality control. All rotors adopt heat treatment methods for drive shaft assembling, and stator winding impregnated with varnish that is heat dried in an industrial oven. The Water Resistance for Pump can reach IP68 Grade.
- HCP's professional assembly line, complimented with a synthesized production test, ensures the highest level of pump quality.
- Standard accessories include : cable with an epoxy resin sealed water-resistant cable base, Auto-cut Protector, dual mechanical seals and lip seal design.
- The A-05A is an extremely practical pump, with a low temperature, oil filled motor and single seal design (CA/CE).

**Semi-open (Vortex Impeller)**

Produces a vortex (whirlpool effect) allowing long fibrous materials and other solid waste to pass through, without contact with the impeller.

**Semi-open**

Excellent to use with waste materials to prevent from clogging.

## APPLICATIONS

- waste water.
- Sump Drainage.
- Flood control.
- Dewatering for fish pond or basement and cellars.

## PRODUCT NOMENCLATURE

A/ AN	—	2	1
Type		Discharge inch	HP

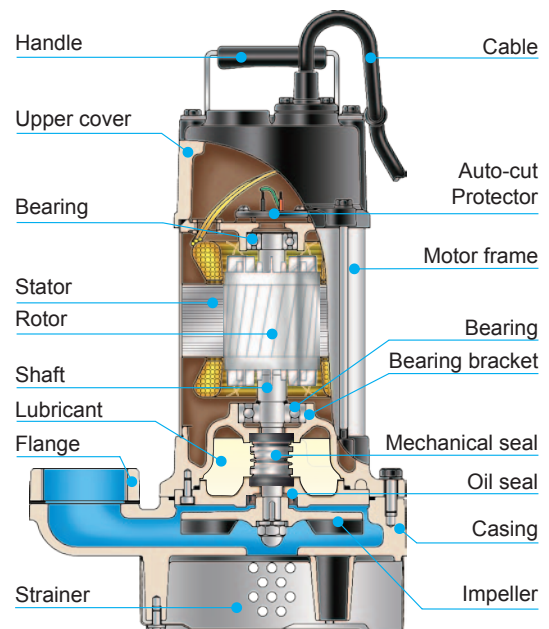



## PERFORMANCE CURVES

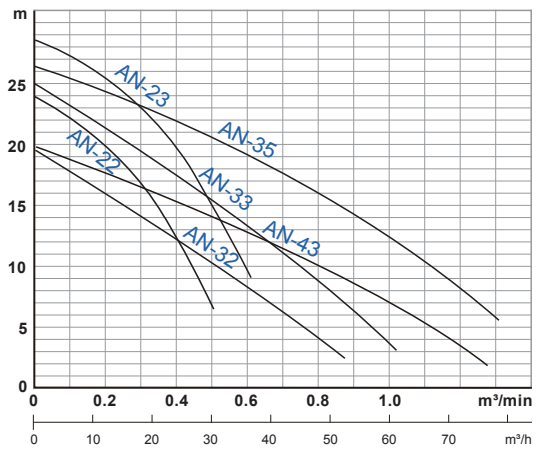
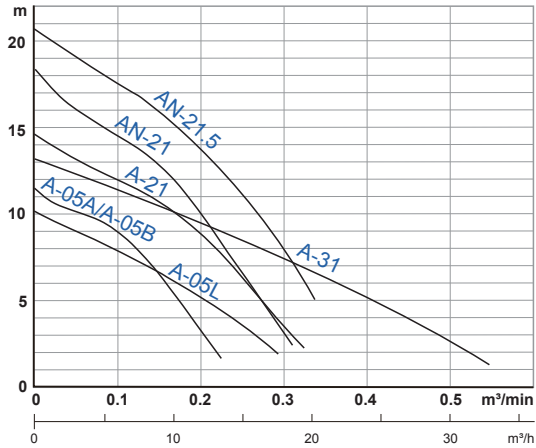

## SPECIFICATIONS

Item		Description
Limits Of Use	Liquid Temp.	0~40°C
	Applications	Wastewater Sewage and Drainage waster
Type	Frequency	50Hz
	Motor	2P(3000rpm) • Dry Motor (A-05A: Oil Motor)
	Insulation	Class B
	Protection	IP68
	Protector	Auto-cut Protector (A-05A/05B/05L 1Ø:Thermal)
	Bearing	Ball Type
	M.seal	Double M.seals (A-05A: Single M.seal)
Material	Impeller	Semi-open
	Upper Cover	FC200
	Motor Frame	SUS304
	Shaft	SUS410 (0.5~1.5HP) • SUS403 (2~5HP)
	M.seal	Upper : Carbon/ceramic Lower : Silicon/Silicon (A-05A: Carbon/Ceramic)
	Casing	FC200
	Impeller	FC200(A-05A/05B : PA)
Optional	Cable	VCT or H07RN-F or SJOW/SOW
	Pumps can be customized to fit specifications Floating Switch (2P: 0.5~3HP)	

## PERFORMANCE SPECS.

Note: Weight Not Included Cable & Elbow Set

Model	Output HP(kW)	Discharge Inch(mm)	Phase Ø	Start Method	Head m	Standard		Solid Passage mm	Weight kg		Dimensions mm				
						m³/min	m³/h		1Ø	3Ø	A	B	C	1Ø	3Ø
A-05A	0.5 (0.4)	2" (50)	1	Capacitor	8	0.1	6	7.5	12	-	225	-	161	349	-
A-05B	0.5 (0.4)	2" (50)	1 3	Capacitor Direct	8	0.1	6	7.5	13	12	225	-	161	371	371
A-05L	0.5 (0.4)	2" (50)	1 3	Capacitor Direct	7	0.15	9	10	16	14	245	-	173	428	428
A-21	1 (0.75)	2" (50)	1 3	Capacitor Direct	10	0.18	10.8	10	17	15	245	-	173	428	428
A-31	1 (0.75)	3" (80)	1 3	Capacitor Direct	6.5	0.3	18	10	18	17	278	-	173	456	456
AN-21	1 (0.75)	2" (50)	1 3	Capacitor Direct	13.5	0.12	7.2	7	18	17	262	-	187	408	408
AN-21.5	1.5 (1.1)	2" (50)	1 3	Capacitor Direct	15	0.16	9.6	7	20	18	262	-	187	428	408
AN-22	2 (1.5)	2" (50)	1 3	Capacitor Direct	18.5	0.25	15	10.5	31	27	282	-	207	580	499
AN-32	2 (1.5)	3" (80)	1 3	Capacitor Direct	10.5	0.5	30	10.5	33	29	391	249	208	591	510
AN-23	3 (2.2)	2" (50)	1 3	Capacitor Direct	23.5	0.3	18	10.5	35	29	282	-	207	592	499
AN-33	3 (2.2)	3" (80)	1 3	Capacitor Direct	15.5	0.5	30	10.5	37	32	391	249	208	603	510
AN-43	3 (2.2)	4" (100)	1 3	Capacitor Direct	11.5	0.7	42	20	37	32	389	248	207	601	520
AN-35	5 (3.7)	3" (80)	3	Direct	19	0.6	36	20	-	35	440	248	207	-	540

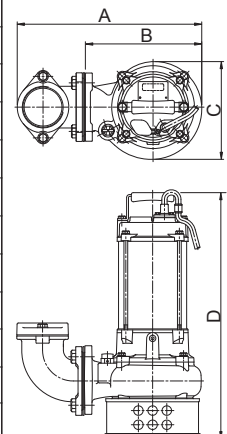



## ACCESSORIES : ELBOW / GRS-GUIDE RAIL SYSTEMS

Pump can be installed with 90 ° elbow , flange or guide rail system, for quick and safe installation, removal, replacement and maintenance.



ELBOW



GRS

## PRODUCT FEATURES



### Epoxy Cable Base

An epoxy resin seal cable base prevents moisture from entering the motor through the core wires.



### Double Mechanical Seals

Superior abrasion resistant mechanical seal manufactured with silicon carbide to ensure the best seal effect.



### Auto-cut Protector

Automatic On/Off motor protector to prevent motor burn out due to high temperature and excess amperage draw.



### High Efficiency Dry Motors

All stator coils need to be treated with insulating varnish procedure to achieving the best insulation, efficiency and durability.



Professionalism • Innovation • Service • Commitment

**HCP PUMP MANUFACTURER CO., LTD.**

[www.hcppump.com.tw](http://www.hcppump.com.tw)



Distributor:

DANEN5-1610